

Description

The AL-285 is a very sturdily constructed two-axle concrete spraying machine for the processing of wet or dry mix.

The machine is suitable either for manual spraying or by means of a robotic arm. The AL-285 is developed for the application of shotcrete in tunnels, mines and slopes.

The machine has been designed especially for steel fibre spraying.

The AL-285 is available as EXTENDED version with electric drive and synchronized to the EXTENDED Dosing unit.

Dimensions with chassis

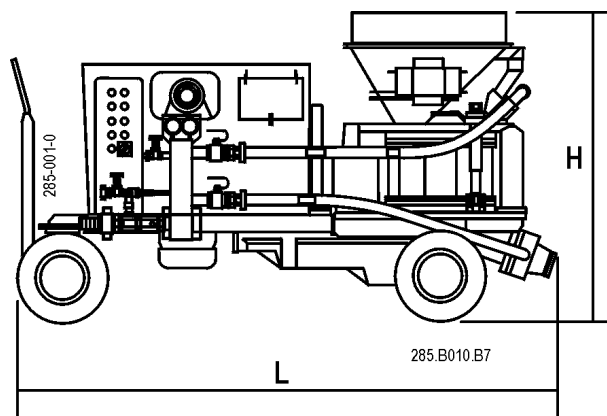

Length L1	:	2460 mm
Width	:	1100 mm
Height H1	:	1410 mm
Weight	:	approx. 1550 kg
Content of hopper	:	100 liters

Dimensions with skid

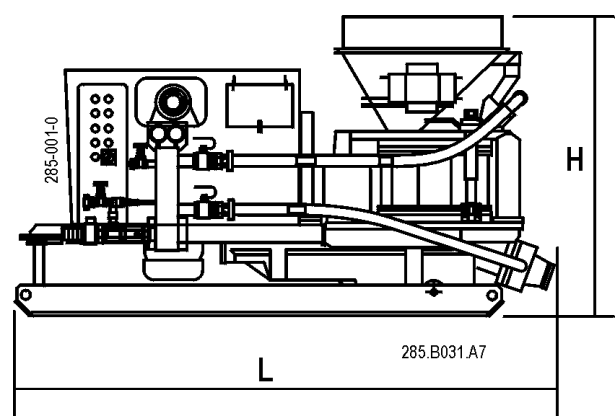

Length L2	:	2380 mm
Width	:	1100 mm
Height H2	:	1310 mm
Weight	:	approx. 1600 kg
Content of hopper	:	100 liters

Drive

Electric

Motor output	:	11 kW
Speed range	:	900 / 2100 rpm
Voltages	:	400 V 50 Hz 400 / 440V 60 Hz 220 V 50 Hz 220 V 60 Hz
Protection	:	IP 55

Technical and design modifications remain reserved at all times. Technical properties have been achieved under theoretical and normal conditions. Please consult the respective machine manual for all matters related to operations and maintenance.

Theoretical conveying data (dry and wet)				
Rotor (Liter)	Hose Ø (mm)	Conveying output ¹⁾ (m ³ /h)	max. grain (mm)	max. conv. dist. (m) Horizontal / Vertical
25	60	8.0 – 11.0	20	Dry: 300 / 100 Wet: 40 / 30
	65	12.0 – 15.0	20	
	80	16.0 – 19.0	25	
	>80	>19.0	30	

1) With theoretical filling degree of 100%, if motor with 60 Hz = 20% higher conveying capacity

Theoretical datas for air consumption for conveying				
Hose Ø (mm)	Air consumption (Nm ³ /min.) ²⁾			²⁾ Air consumption data are approximate values and are depending on conveying output, conveying distance and hose diameter. 1 Nm ³ /min. = 35 cfm
	Dry spraying		Wet spraying	
	60 m	120 m	40 m	
60	11	13,5	15	
65	13	15,5	18,5	
80	16	20	24	
>80	>16	>20	>24	

AL-285 EXTENDED

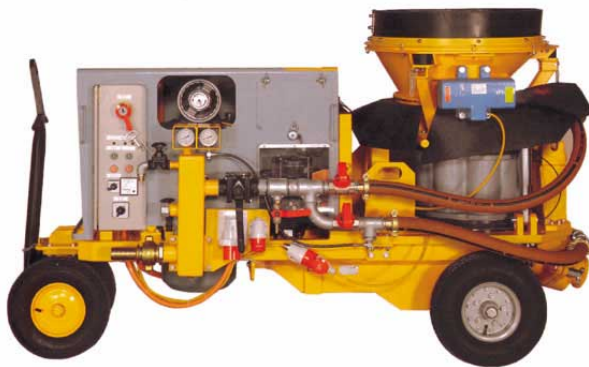

Technical and design modifications remain reserved at all times. Technical properties have been achieved under theoretical and normal conditions. Please consult the respective machine manual for all matters related to operations and maintenance.